

# **Practical Woodwork: Planning for Manufacture Tools and Machines**

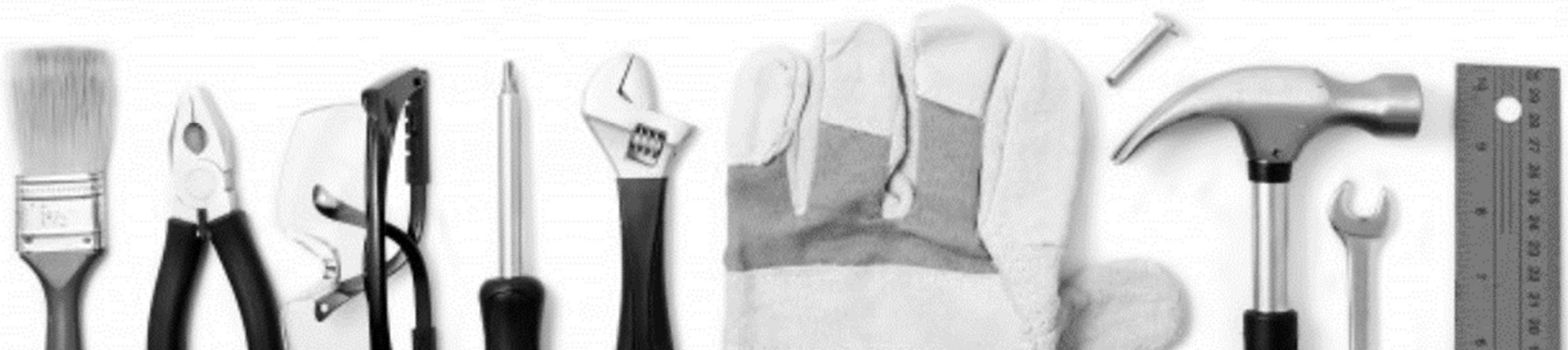

**In class we are used to carrying out basic woodworking tasks what we need to build on is our ability to look at the project drawings and plan our next steps.**

**For your N4 and N5 assignment you will need to plan and carry out the whole project independently. That means no asking what you need to do next!**

**Task: Answer the questions on the tools and processes used to build and assemble the three projects you have created cutting lists for.**



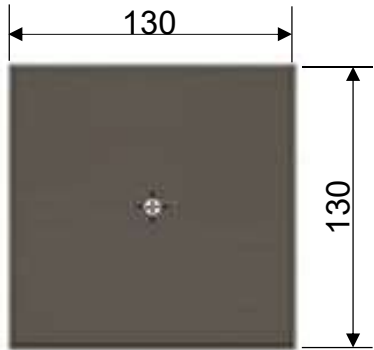

CLOCKFACE

**Q1 : There are two ways to mark out the centre of the clockface for drilling. Describe one way this could be done. You must name any tools or equipment used.**

**A1:** \_\_\_\_\_  
 \_\_\_\_\_  
 \_\_\_\_\_  
 \_\_\_\_\_

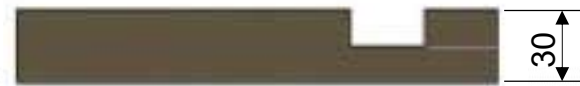

SIDES

**Q2 : The four sides of wood connected to create a small frame. Name the joint used.**

**A2:** \_\_\_\_\_  
 \_\_\_\_\_

**A3:**  
**Marking out step 1: Using a steel rule and a tri square** \_\_\_\_\_  
**Marking out step 2: Set a marking gauge to** \_\_\_\_\_  
**Cutting step 1:** \_\_\_\_\_  
**cut down the lines until** \_\_\_\_\_  
**Cutting step 2:** \_\_\_\_\_

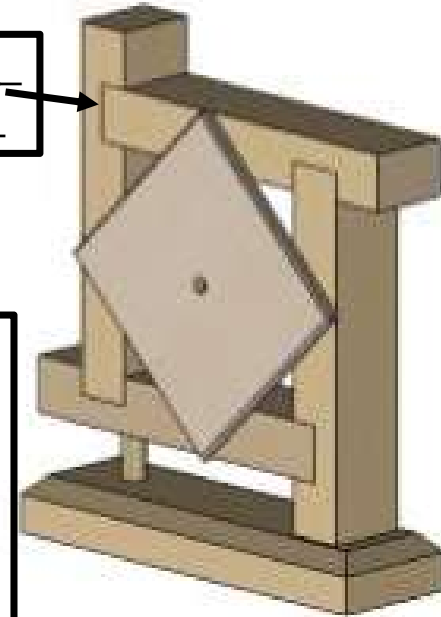

**Q3 : Complete the steps taken to mark out and cut this joint. Refer to sizes, tools or equipment used.**



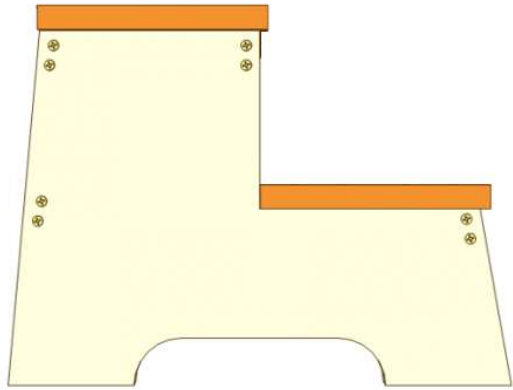

**Q4:** The top of the steps and the sides have to have a different finish. Name two finishes that could have been used.

**A4:**  
Finish for the step: \_\_\_\_\_  
Finish for the side: \_\_\_\_\_

**Q5:** Screws were used to join the rails to the sides.  
Name an alternative method of attaching the rails

**A5:** \_\_\_\_\_  
\_\_\_\_\_

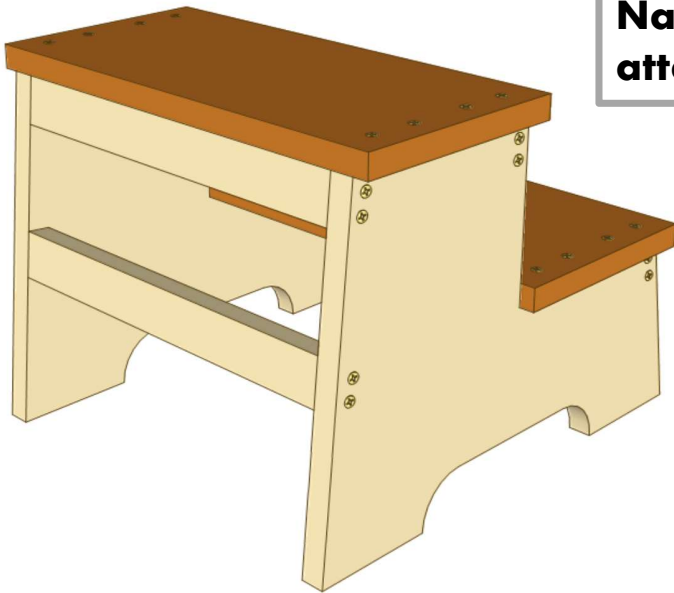

**Q6:** The holes for the screws were drilled on the pillar drill. State two safety checks you would need to make to the machine before you began drilling

**A6:** Safety check 1:  
\_\_\_\_\_  
\_\_\_\_\_  
Safety Check 2:  
\_\_\_\_\_  
\_\_\_\_\_



# Woodwork Handtools

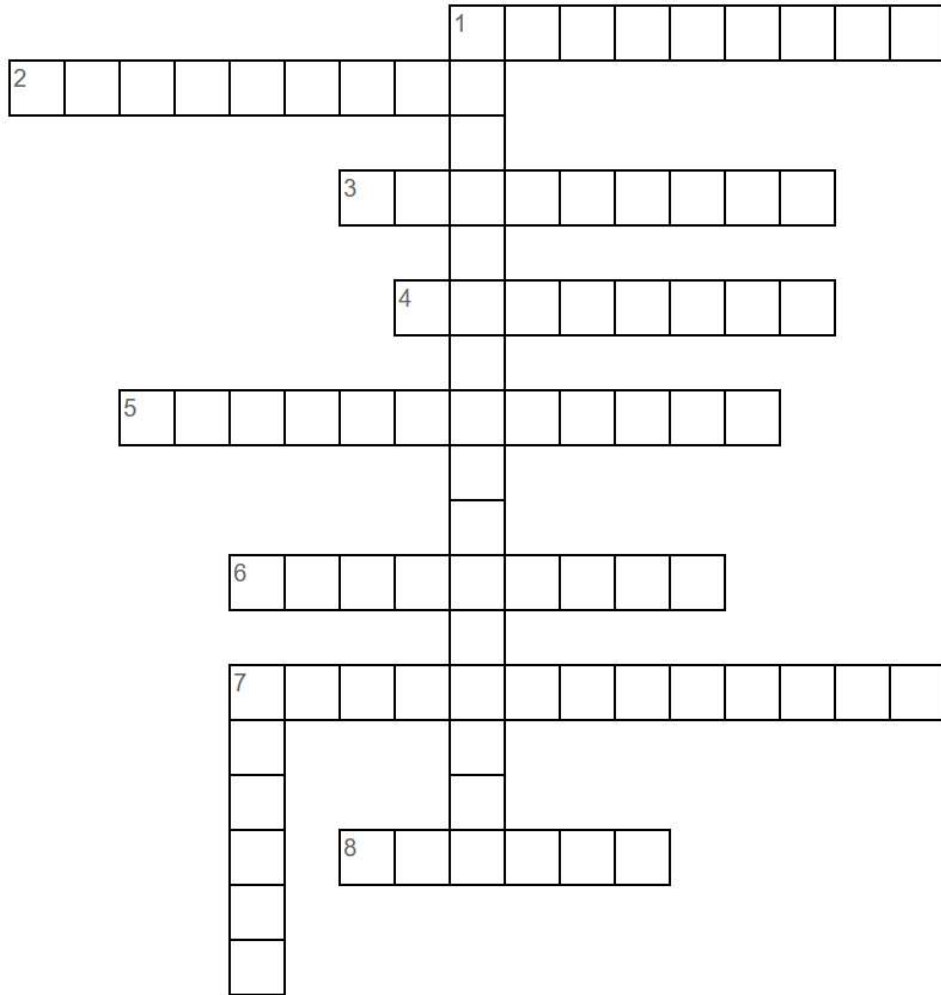

Name the tools below to complete the crossword

Across

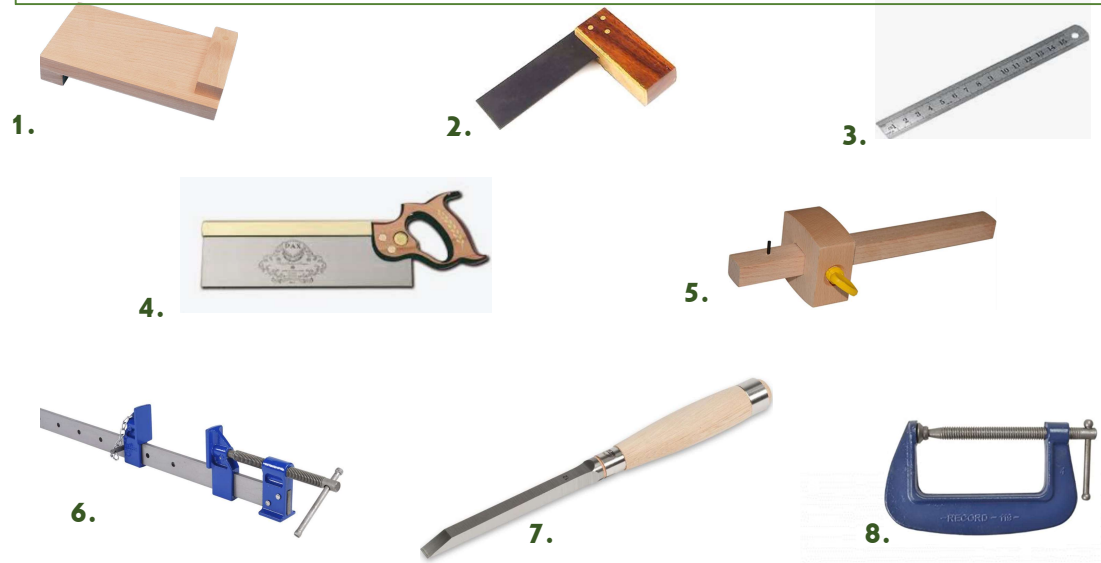

Down

