

# **Practical Woodwork: Week 4**

## **Cutting Lists and Sequence of Operations**

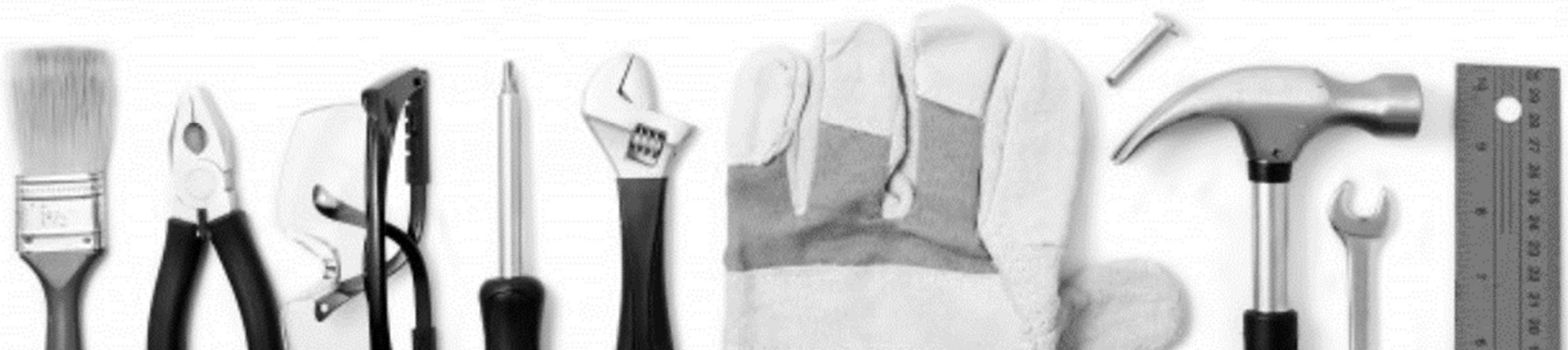

**In class we have completed a few exercises to practice reading information from a working drawing and using that information to create a cutting list.**

**At N4 and N5 you will need to use this skill in class and in the exam.**

**Task: I have attached a 2 project images and sizes. Use the information from the working drawing to create an appropriate cutting list and sequence of operations**



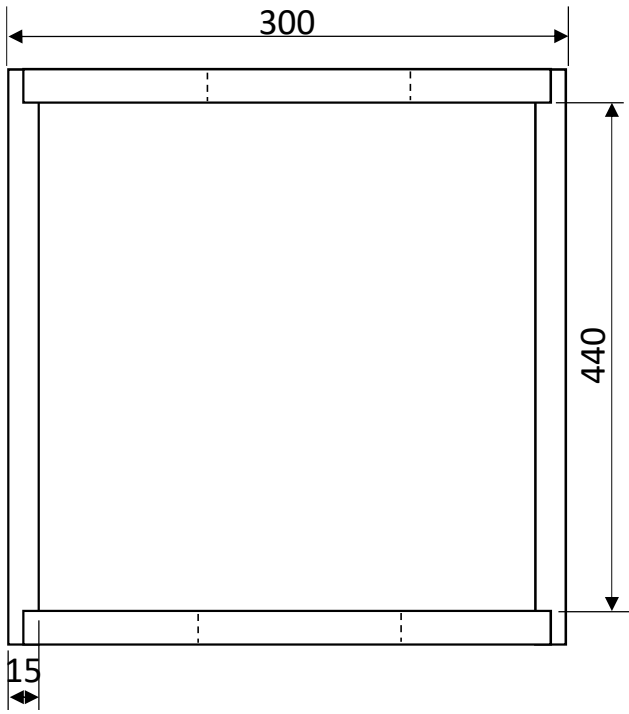

Part	Quantity	Length	Width	Thickness
Base				4mm
Ends				
Sides				

**Task 1 : Complete the cutting list shown above. Answers can be emailed to me or you and write them down and send or upload an image of your cutting list.**

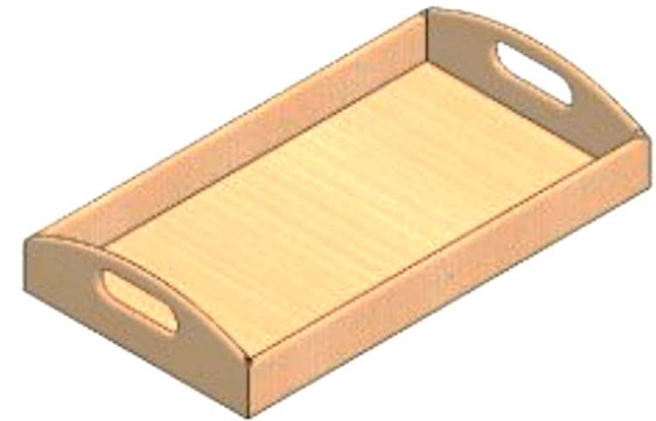
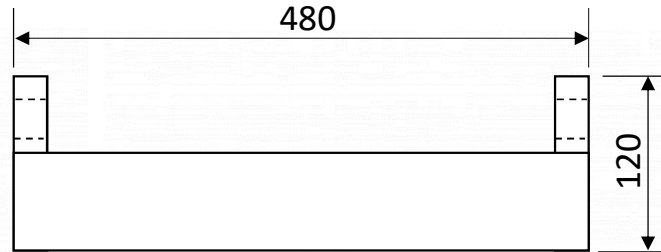
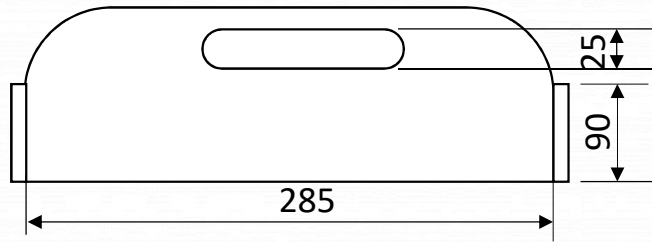

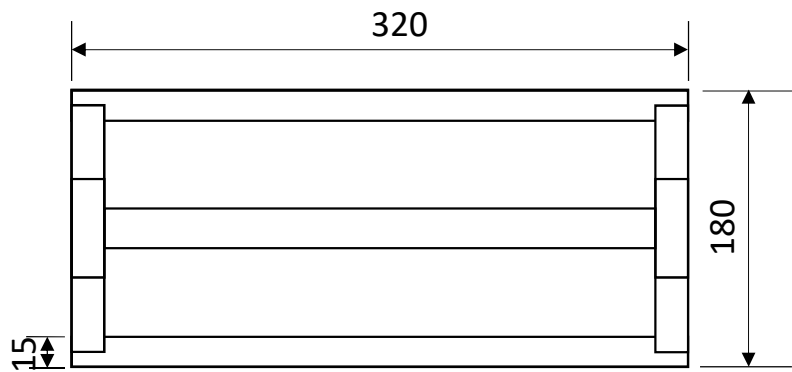

**Task2 : Complete the cutting list shown below. Answers can be emailed to me or you and write them down and send or upload an image of your cutting list.**

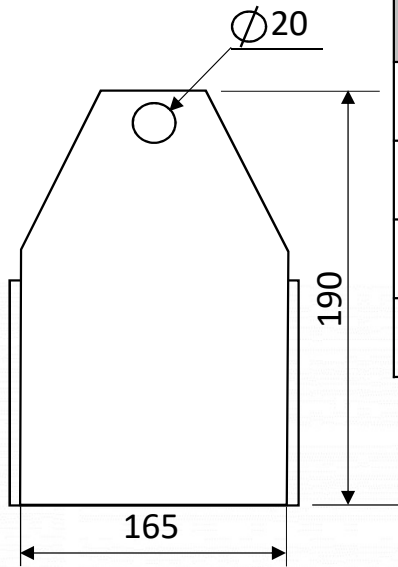
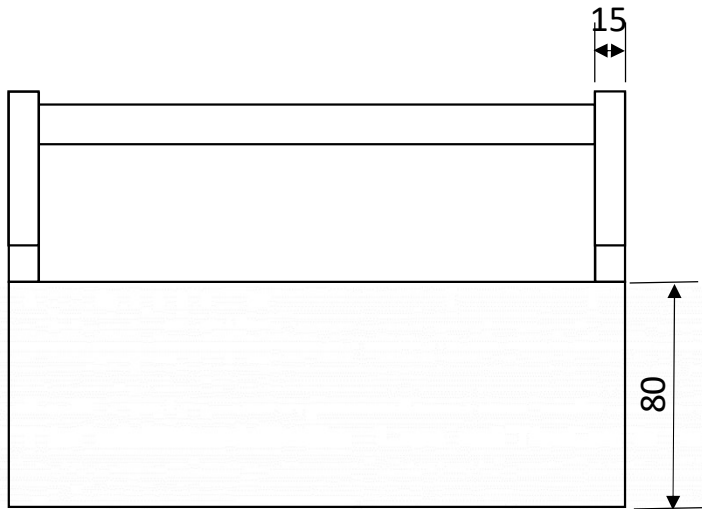
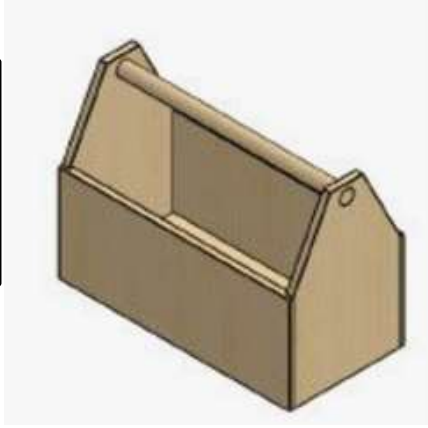

Part	Quantity	Length	Width	Thickness
Sides				
Ends				
Handle	1			n/a
Base	1			4mm



**Task3 : Imagine you were making the toolbox. Talk me through making the item step by step and let me know what tools you would be using as you go. Remember things can normally be broken down into 3 types of tasks marking out, cutting and then assembling.**

